

Installation

Commercial Mobile Generator Sets



Models:

5ERKM

4EFRKM

ISO 9001
KOHLER
GENERATORS
INTERNATIONALLY REGISTERED

KOHLER[®]
POWER SYSTEMS

TP-6082 4/00

Table of Contents

Safety Precautions and Instructions	I	Section 6 Electrical System	11
Section 1 Introduction	1	6.1 Electrical Connections	11
1.1 Installation Standards	1	6.2 AC Load Lead Connections	11
1.2 Generator Set Specifications	1	6.3 Circuit Protection	12
1.3 Generator Set Operation	1	6.3.1 Circuit Breaker Considerations	12
Section 2 Location and Mounting	3	6.3.2 Circuit Breaker Installation	13
2.1 General Considerations	3	6.4 Battery and Connections	14
2.2 Location	3	6.5 Remote Switch Connection	14
2.3 Vehicle-Floor Mounting	3	Section 7 Installation Drawing	15
2.4 Extended-Shaft Mounting	4	Section 8 Reconnection/Adjustments	17
Section 3 Cooling System	5	8.1 Four-Lead Reconnection	17
3.1 Air Requirements	5	8.2 Voltage Regulator Adjustment	19
Section 4 Exhaust System	7	Appendix A Generator Selection and Wattage Requirements	A-1
4.1 Planning	8	Appendix B Abbreviations	A-3
4.2 Clearance Requirements	8		
4.3 Exhaust Piping, If Used	8		
Section 5 Fuel System	9		
5.1 Fuel Tank	9		
5.2 Fuel Lines	10		
5.3 Fuel Pump Lift	10		
5.4 Fuel Consumption	10		

Safety Precautions and Instructions

Electromechanical equipment, including generator sets, transfer switches, switchgear, and accessories, can cause bodily harm and pose life-threatening danger when improperly installed, operated, or maintained. To prevent accidents be aware of potential dangers and act safely. Read and follow all safety precautions and instructions. **SAVE THESE INSTRUCTIONS.**

This manual has several types of safety precautions and instructions: Danger, Warning, Caution, and Notice.

DANGER

Danger indicates the presence of a hazard that **will cause severe personal injury, death, or substantial property damage.**

WARNING

Warning indicates the presence of a hazard that **can cause severe personal injury, death, or substantial property damage.**

CAUTION

Caution indicates the presence of a hazard that **will or can cause minor personal injury or property damage.**

NOTICE

Notice communicates installation, operation, or maintenance information that is safety related but not hazard related.

Safety decals affixed to the equipment in prominent places alert the operator or service technician to potential hazards and explain how to act safely. The decals are shown throughout this publication to improve operator recognition. Replace missing or damaged decals.

Accidental Starting

WARNING

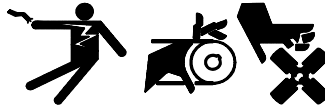

Accidental starting. Can cause severe injury or death.

Disconnect the battery cables before working on the generator set. Remove the negative (-) lead first when disconnecting the battery. Reconnect the negative (-) lead last when reconnecting the battery.

Disabling the generator set. Accidental starting can cause severe injury or death. Before working on the generator set or equipment connected to the set, disable the generator set as follows: (1) Disconnect the power to the battery charger, if equipped. (2) Remove the battery cables, negative (-) lead first. Reconnect the negative (-) lead last when reconnecting the battery. Follow these precautions to prevent the starting of the generator set by the remote start/stop switch.

Battery

WARNING



Sulfuric acid in batteries. Can cause severe injury or death.

Wear protective goggles and clothing. Battery acid may cause blindness and burn skin.

Battery acid. Sulfuric acid in batteries can cause severe injury or death. Sulfuric acid in the battery can cause blindness and burn skin. Always wear splashproof safety goggles when working near the battery. If battery acid splashes in the eyes or on the skin, immediately flush the affected area for 15 minutes with large quantities of clean water. Seek immediate medical aid in the case of eye contact. Never add acid to a battery after placing the battery in service, as this may result in hazardous spattering of battery acid.

Battery gases. Explosion can cause severe injury or death. Battery gases can cause an explosion. Do not smoke or permit flames or sparks to occur near a battery at any time, particularly when it is charging. To prevent burns and sparks that could cause an explosion, avoid touching the battery terminals with tools or other metal objects. Remove wristwatch, rings, and other jewelry before handling the battery. Never connect the negative (-) battery cable to the positive (+) connection terminal of the starter solenoid. Do not test the battery condition by shorting the terminals together. Sparks could ignite the battery gases or fuel vapors. Ventilate the compartments containing batteries to prevent accumulation of explosive gases. To avoid sparks, do not disturb the battery charger connections while the battery is charging. Always turn the battery charger off before disconnecting the battery connections. Remove the negative (-) lead first when disconnecting the battery. Reconnect the negative (-) lead last when reconnecting the battery.

Engine Backfire/Flash Fire

⚠ WARNING

Fire. Can cause severe injury or death. Do not smoke or permit flames or sparks near fuels or the fuel system.

Servicing the fuel system. A flash fire can cause severe injury or death. Do not smoke or permit flames or sparks near the carburetor, fuel line, fuel filter, fuel pump, or other potential sources of spilled fuels or fuel vapors. Catch fuels in an approved container when removing the fuel line or carburetor.

Servicing the air cleaner. A sudden backfire can cause severe injury or death. Do not operate the generator set with the air cleaner removed.

Combustible materials. A fire can cause severe injury or death. Generator set engine fuels and fuel vapors are flammable and explosive. Handle these materials carefully to minimize the risk of fire or explosion. Equip the compartment or nearby area with a fully charged fire extinguisher. Select a fire extinguisher rated ABC or BC for electrical fires or as recommended by the local fire code or an authorized agency. Train all personnel on fire extinguisher operation and fire prevention procedures.

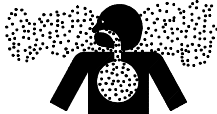
Exhaust System

⚠ WARNING

Carbon monoxide. Can cause severe nausea, fainting, or death. The exhaust system must be leakproof and routinely inspected.

Generator set operation. Carbon monoxide can cause severe nausea, fainting, or death. Carbon monoxide is an odorless, colorless, tasteless, nonirritating gas that can cause death if inhaled for even a short time. Avoid breathing exhaust fumes when working on or near the generator set. Never operate the generator set inside a building unless the exhaust gas is piped safely outside. Never operate the generator set where exhaust gas could accumulate and seep back inside a potentially occupied building or vehicle. Do not obstruct the exhaust outlet when parking your vehicle. The exhaust gases must discharge freely to prevent carbon monoxide from deflecting into the vehicle.

Carbon monoxide symptoms. Carbon monoxide can cause severe nausea, fainting, or death. Carbon monoxide is a poisonous gas present in exhaust gases. Carbon monoxide poisoning symptoms include but are not limited to the following:

- Light-headedness, dizziness
 - Physical fatigue, weakness in joints and muscles
 - Sleepiness, mental fatigue, inability to concentrate or speak clearly, blurred vision
 - Stomachache, vomiting, nausea
- If experiencing any of these symptoms and carbon monoxide poisoning is possible, seek fresh air immediately and remain active. Do not sit, lie down, or fall asleep. Alert others to the possibility of carbon monoxide poisoning. Seek medical attention if the condition of affected persons does not improve within minutes of breathing fresh air.

Installing the exhaust tail pipe. Carbon monoxide can cause severe nausea, fainting, or death. Install the exhaust system tail pipe to prevent the drawing of discharged exhaust gases into the vehicle interior through windows, doors, air conditioners, and other openings. Do not use flexible tail piping because it could crack and allow lethal exhaust fumes to enter the vehicle.

Inspecting the exhaust system. Carbon monoxide can cause severe nausea, fainting, or death. For the safety of the vehicle's occupants, install a carbon monoxide detector. Consult the coach builder or dealer for approved detector location and installation. Inspect the detector before each generator set use. In addition to routine exhaust system inspection, test the carbon monoxide detector per the manufacturer's instructions and keep the detector operational at all times.

Fuel System

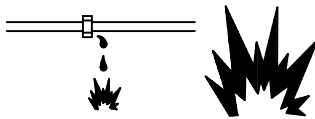
⚠ WARNING

Explosive fuel vapors. Can cause severe injury or death. Use extreme care when handling, storing, and using fuels.

The fuel system. Explosive fuel vapors can cause severe injury or death. Vaporized fuels are highly explosive. Use extreme care when handling and storing fuels. Store fuels in a well-ventilated area away from spark-producing equipment and out of the reach of children. Never add fuel to the tank while the engine is running because spilled fuel may ignite on contact with hot parts or from sparks. Do not smoke or permit flames or sparks to occur near sources of spilled fuel or fuel vapors. Keep the fuel lines and connections tight and in good condition. Do not replace flexible fuel lines with rigid lines. Use flexible sections to avoid fuel line breakage caused by vibration. Do not operate the generator set in the presence of fuel leaks, fuel accumulation, or sparks. Repair fuel systems before resuming generator set operation.

Explosive fuel vapors can cause severe injury or death. Take additional precautions when using the following fuels:

Gasoline—Store gasoline only in approved red containers clearly marked GASOLINE.

Draining the fuel system. Explosive fuel vapors can cause severe injury or death. Spilled fuel can cause an explosion. Use a container to catch fuel when draining the fuel system. Wipe up spilled fuel after draining the system.

Hazardous Noise

⚠ CAUTION



Hazardous noise.
Can cause hearing loss.

Never operate the generator set without a muffler or with a faulty exhaust system.

Engine noise. Hazardous noise can cause hearing loss. Generator sets not equipped with sound enclosures can produce noise levels greater than 105 dBA. Prolonged exposure to noise levels greater than 85 dBA can cause permanent hearing loss. Wear hearing protection when near an operating generator set.

Hazardous Voltage/ Electrical Shock

⚠ WARNING	
Hazardous voltage. Moving rotor. Can cause severe injury or death.	
Operate the generator set only when all guards and electrical enclosures are in place.	

Grounding electrical equipment. Hazardous voltage can cause severe injury or death. Electrocutation is possible whenever electricity is present. Open the main circuit breakers of all power sources before servicing the equipment. Configure the installation to electrically ground the generator set, transfer switch, and related equipment and electrical circuits to comply with applicable codes and standards. Never contact electrical leads or appliances when standing in water or on wet ground because these conditions increase the risk of electrocution.

Short circuits. Hazardous voltage/current can cause severe injury or death. Short circuits can cause bodily injury and/or equipment damage. Do not contact electrical connections with tools or jewelry while making adjustments or repairs. Remove wristwatch, rings, and jewelry before servicing the equipment.

Testing the voltage regulator. Hazardous voltage can cause severe injury or death. High voltage is present at the voltage regulator heat sink. To prevent electrical shock do not touch the voltage regulator heat sink when testing the voltage regulator. (*PowerBoost™, PowerBoost™ III, and PowerBoost™ V voltage regulator models only*)

Electrical backfeed to the utility. Hazardous backfeed voltage can cause severe injury or death. Connect the generator set to the building/campground electrical system only through an approved device and after the building/campground main switch is opened. Backfeed connections can cause serious injury or death to utility personnel working on power lines and/or personnel near the work area. Some states and localities prohibit unauthorized connection to the utility electrical system. Install a transfer switch to prevent interconnection of the generator set power and other sources of power.

Hot Parts



⚠ WARNING
Hot engine and exhaust system. Can cause severe injury or death.
Do not work on the generator set until it cools.



Servicing the exhaust system. Hot parts can cause severe injury or death. Do not touch hot engine parts. The engine and exhaust system components become extremely hot during operation.

Combustible materials. Fire can cause severe injury or death. A hot exhaust system can ignite adjacent combustible materials. Do not locate electrical wiring, fuel lines, or combustible materials above the exhaust muffler. Exercise caution when parking your vehicle to prevent the exhaust system and hot exhaust gases from starting grass fires.

Combustible materials. Fire can cause severe injury or death. A hot generator set can ignite debris in the compartment. Keep the compartment and generator set clean and free of debris and combustible materials to minimize the possibility of fire. Do not block the fuel/oil drain opening in the generator set mounting tray. Cut a corresponding hole in the subfloor, if used, for the drain opening.

Moving Parts

⚠ WARNING	
	
Hazardous voltage. Moving rotor. Can cause severe injury or death.	
Operate the generator set only when all guards and electrical enclosures are in place.	

⚠ WARNING	
	
Rotating parts. Can cause severe injury or death.	
Operate the generator set only when all guards, screens, and covers are in place.	

Tightening the hardware. Flying projectiles can cause severe injury or death. Loose hardware can cause the hardware or pulley to release from the generator set engine and can cause personal injury. Retorque all crankshaft and rotor hardware after servicing. Do not loosen the crankshaft hardware or rotor thru-bolt when making adjustments or servicing the generator set. Rotate the crankshaft manually in a clockwise direction only. Turning the crankshaft bolt or rotor thru-bolt counterclockwise can loosen the hardware.

Servicing the generator set when it is operating. Exposed moving parts can cause severe injury or death. Keep hands, feet, hair, clothing, and test leads away from the belts and pulleys when the generator set is running. Replace guards, screens, and covers before operating the generator set.

Notice

NOTICE
This generator set has been rewired from its nameplate voltage to

<small>246242</small>

NOTICE

Voltage reconnection. Affix a notice to the generator set after reconnecting the set to a voltage different from the voltage on the nameplate. Order voltage reconnection decal 246242 from an authorized service distributor/dealer.

NOTICE

Hardware damage. The engine and generator set may use both American Standard and metric hardware. Use the correct size tools to prevent rounding of the bolt heads and nuts.

NOTICE

When replacing hardware, do not substitute with inferior grade hardware. Screws and nuts are available in different hardness ratings. To indicate hardness, American Standard hardware uses a series of markings, and metric hardware uses a numeric system. Check the markings on the bolt heads and nuts for identification.

NOTICE

Canadian installations only. For standby service connect the output of the generator set to a suitably rated transfer switch in accordance with Canadian Electrical Code, Part 1.

NOTICE

This generator set does not comply with United States Coast Guard (USCG) requirements and must not be used for marine applications. For marine installations use only generator sets specified for marine use. USCG Regulation 33CFR183 requires that a generator set must be ignition protected when used in a gasoline-fueled environment.

This manual provides installation instructions for 5ERKM/4EFRKM model generator sets. Operation manuals are available separately.

Information in this publication represents data available at the time of print. Kohler Co. reserves the right to change this publication and the products represented without notice and without any obligation or liability whatsoever.

x:in:001:003:a

1.1 Installation Standards

Mobile generator set installations must comply with the Kohler-detailed installation instructions following and state and local requirements.

The installer is responsible for improper installations resulting in penalties from noncompliance with CARB or EPA emission standards.

1.2 Generator Set Specifications

Refer to the model's specification sheet for details. Use the specification sheet as a guide for planning the installation. See Section 7 for the dimension drawing and the operation manual for the wiring diagram.

1.3 Generator Set Operation

After the installer attaches the generator set to the vehicle's frame and connects the hoses, do the following to make the generator set operational:

- Attach the exhaust system
- Add oil to the engine crankcase to the specified capacity
- Connect the fuel line
- Connect the remote switch, if equipped
- Connect the load leads
- Connect the battery terminals

Refer to the operation manual for operating instructions.

Notes

Section 2 Location and Mounting

2.1 General Considerations

Consider the following items concerning the generator set and Section 2.2 for the proposed location:

1. Select a generator set having adequate capacity to handle the electrical load.
2. Design the fuel system to prevent fuel starvation of the main or generator set engine.
3. Ensure that the exhaust system meets all safety requirements after installation.
4. Ensure compatibility of all electrical systems (battery, load, and remote switch) with the vehicle's electrical systems.

2.2 Location

Note: This generator set is not designed for installation in a compartment or enclosure.

Before making final plans for locating the generator set, ensure the following:

1. The location has sufficient room to maintain required minimum clearances. See Section 2.3.
2. The location provides enough air flow to allow required cooling and combustion. See Section 3.1.
3. The location can support the generator set's weight. See the generator set specification sheet.
4. The location provides ample room for routine service of the generator set's engine, controller, and fuel system components. See the generator set specification sheet or Section 7.

For angular operating limits, consult the operation manual.

2.3 Vehicle-Floor Mounting

Install the Kohler 5ERKM/4EFRKM mobile generator set on an open vehicle's floor or truck bed. Follow the guidelines below. Contact an authorized Kohler service distributor/dealer with your specific application questions.

Minimum clearance. Allow clearance for vibration and cooling during operation. Minimum clearance for vibration (top, front, rear, and sides) is 38 mm (1 1/2 in.). Keep the air inlets unobstructed for proper air flow.

Additional clearance. Generator set service requires more clearance than 38 mm (1 1/2 in.). Design the mounting location to allow for sufficient room to easily remove the generator set to perform major service.

Mounting tray. Ensure that the structural members for mounting can support the generator set's weight and withstand vibration. The generator set includes vibration mounts and a mounting tray; if desired, install additional vibration isolating pads underneath the generator set's base. Use the four mounting holes in the mounting tray to mount the generator set securely to the vehicle to avoid unwanted movement from vibration and road shock.

2.4 Extended-Shaft Mounting

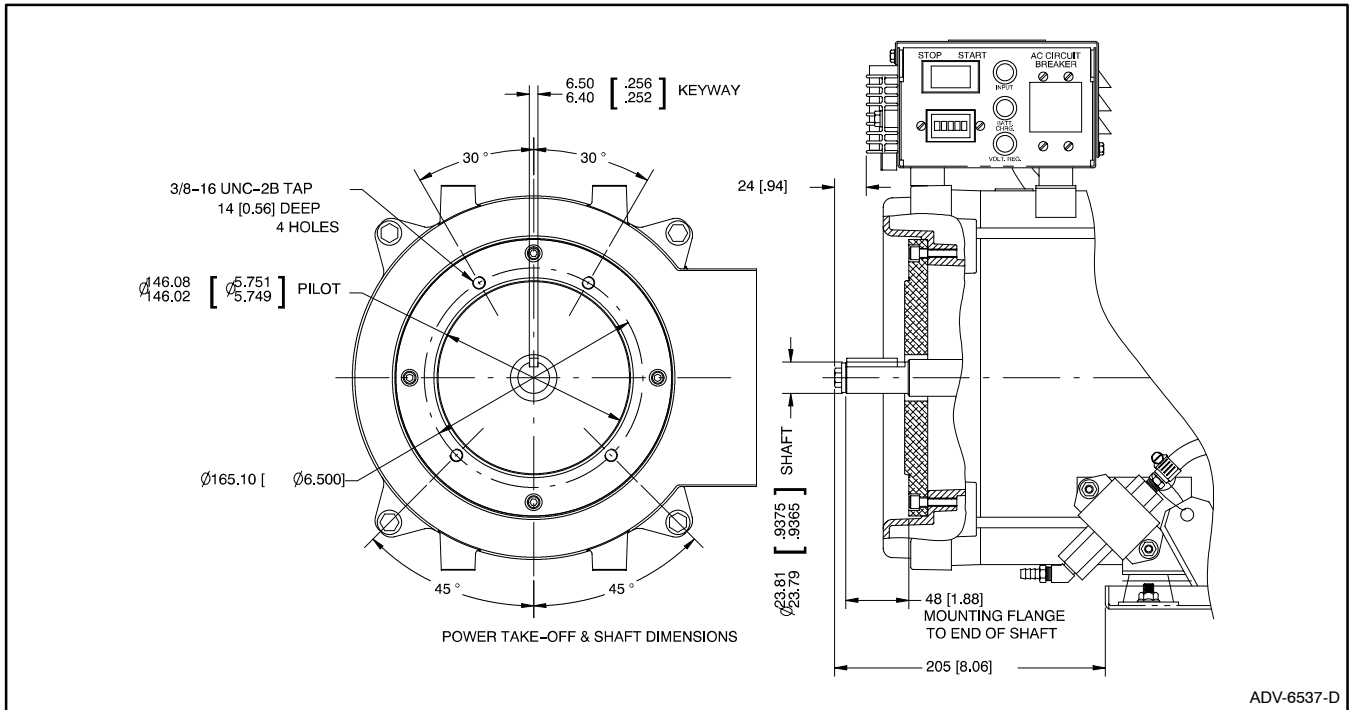

Figure 2-1 Extended Shaft Dimensions

If the mobile generator set includes an extended shaft, allow adequate space at the generator end of the set for an adapter, a flexible coupling, and the operating equipment. The mounting flange conforms to SAE J609a, Flange B. See Figure 2-1 for dimensions.

Note: Customers must provide the adapter and flexible coupling for the extended-shaft option.

Figure 2-2 shows a Kohler mobile generator set mounted to a hydraulic pump. The generator set equipped with the extended-shaft option can power external equipment to the limit of the engine's capacity.

Note: The PTO extended shaft can pull maximum horsepower. The extended shaft is designed for powering a direct-driven hydraulic pump.

Note: Adding a hydraulic pump drive lowers the engine horsepower available to drive the generator. Therefore, the engine can overload. Be aware of reduced generator output when powering external equipment.

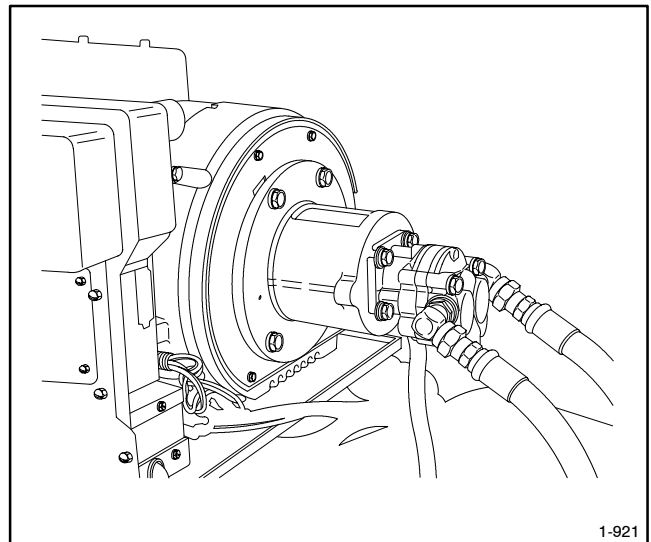

Figure 2-2 Hydraulic Pump

3.1 Air Requirements

Air flow around the generator set is necessary for adequate cooling. See the generator set specification sheet for air requirements. The air intake silencer/cleaner provides combustion air to the engine. See Figure 3-1 for allowable intake restriction. Follow these guidelines to optimize generator set performance.

Model	Maximum Air Intake Restriction
5ERKM/4EFRKM	7.87 in. H ₂ O (0.28 psi)

Figure 3-1 Intake Restriction

Notes

Section 4 Exhaust System

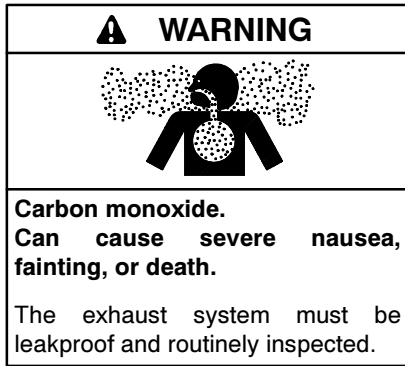

Generator set operation. Carbon monoxide can cause severe nausea, fainting, or death. Carbon monoxide is an odorless, colorless, tasteless, nonirritating gas that can cause death if inhaled for even a short time. Avoid breathing exhaust fumes when working on or near the generator set. Never operate the generator set inside a building unless the exhaust gas is piped safely outside. Never operate the generator set where exhaust gas could accumulate and seep back inside a potentially occupied building or vehicle. Do not obstruct the exhaust outlet when parking your vehicle. The exhaust gases must discharge freely to prevent carbon monoxide from deflecting into the vehicle.

Carbon monoxide symptoms. Carbon monoxide can cause severe nausea, fainting, or death. Carbon monoxide is a poisonous gas present in exhaust gases. Carbon monoxide poisoning symptoms include but are not limited to the following:

- Light-headedness, dizziness
- Physical fatigue, weakness in joints and muscles
- Sleepiness, mental fatigue, inability to concentrate or speak clearly, blurred vision
- Stomachache, vomiting, nausea

If experiencing any of these symptoms and carbon monoxide poisoning is possible, seek fresh air immediately and remain active. Do not sit, lie down, or fall asleep. Alert others to the possibility of carbon monoxide poisoning. Seek medical attention if the condition of affected persons does not improve within minutes of breathing fresh air.

Installing the exhaust tail pipe. Carbon monoxide can cause severe nausea, fainting, or death. Install the exhaust system tail pipe to prevent the drawing of discharged exhaust gases into the vehicle interior through windows, doors, air conditioners, and other openings. Do not use flexible tail piping because it could crack and allow lethal exhaust fumes to enter the vehicle.

Inspecting the exhaust system. Carbon monoxide can cause severe nausea, fainting, or death. For the safety of the vehicle's occupants, install a carbon monoxide detector. Consult the coach builder or dealer for approved detector location and installation. Inspect the detector before each generator set use. In addition to routine exhaust system inspection, test the carbon monoxide detector per the manufacturer's instructions and keep the detector operational at all times.

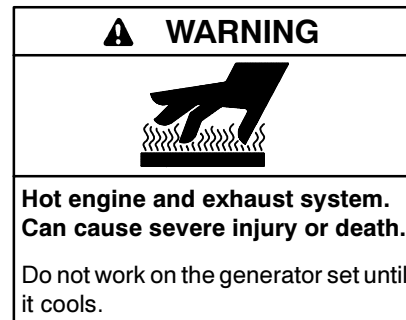

Combustible materials. Fire can cause severe injury or death. A hot exhaust system can ignite adjacent combustible materials. Do not locate electrical wiring, fuel lines, or combustible materials above the exhaust muffler. Exercise caution when parking your vehicle to prevent the exhaust system and hot exhaust gases from starting grass fires.

4.1 Planning

Carefully plan the generator exhaust system installation to ensure a safe, quiet operation. Verify that the installation complies with all state and local requirements.

4.2 Clearance Requirements

Kohler Co. recommends a clearance of 38 mm (1 1/2 in.) between the exhaust system parts and the fuel system, the electrical system, and all combustible components to protect the generator set components and to avoid igniting adjacent combustible materials.

4.3 Exhaust Piping, If Used

Route the exhaust piping to meet minimum clearances and to minimize exhaust piping bends. Use a tail pipe that is as short as possible with as few bends as possible to reduce back pressure. Design the exhaust piping to prevent excessive back pressure of the unit-mounted muffler. See Figure 4-1 for the allowable exhaust back pressure. Do not apply weight or pressure to the unit-mounted muffler, otherwise premature exhaust-system damage will occur. Adding exhaust-pipe extensions to the unit-mounted muffler may cause excessive vibration and noise transmitted to the vehicle. If using a fixed-mounted exhaust pipe, use a stainless steel flexible exhaust section between the muffler outlet and the exhaust pipe inlet.

Model	Allowable Exhaust Back Pressure
5ERKM/4EFRKM	37.50 in. H ₂ O

Figure 4-1 Allowable Exhaust Back Pressure

⚠ WARNING



**Explosive fuel vapors.
Can cause severe injury or death.**

Use extreme care when handling, storing, and using fuels.

The fuel system. Explosive fuel vapors can cause severe injury or death. Vaporized fuels are highly explosive. Use extreme care when handling and storing fuels. Store fuels in a well-ventilated area away from spark-producing equipment and out of the reach of children. Never add fuel to the tank while the engine is running because spilled fuel may ignite on contact with hot parts or from sparks. Do not smoke or permit flames or sparks to occur near sources of spilled fuel or fuel vapors. Keep the fuel lines and connections tight and in good condition. Do not replace flexible fuel lines with rigid lines. Use flexible sections to avoid fuel line breakage caused by vibration. Do not operate the generator set in the presence of fuel leaks, fuel accumulation, or sparks. Repair fuel systems before resuming generator set operation.

Draining the fuel system. Explosive fuel vapors can cause severe injury or death. Spilled fuel can cause an explosion. Use a container to catch fuel when draining the fuel system. Wipe up spilled fuel after draining the system.

5.1 Fuel Tank

Fuel system design. Design the generator set gasoline fuel system to operate independently of the vehicle engine fuel system if the operator may operate both engines simultaneously. Kohler Co. recommends using separate fuel tanks, if possible; however, using separate fuel tanks is usually impractical because of space restrictions. In most installations, both engines operate off a common tank with a dual dip-tube arrangement as shown in Figure 5-1. The dip-tube arrangement prevents the larger engine from starving the smaller engine of fuel. The generator set dip tube is generally shorter than the vehicle dip tube to stop the generator set before the vehicle engine runs out of fuel. With the dual dip-tube arrangement, the generator may not get fuel during a low fuel-supply situation.

Tee arrangement. Do not use the tee arrangement. Do not tee into the fuel-supply or -return line of fuel-injected systems.

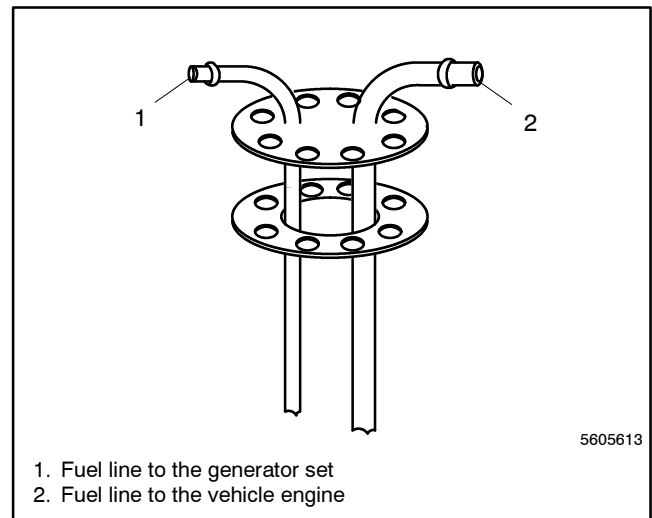

Figure 5-1 Two Dip Tubes in Fuel Tank

Note: Consult an authorized Kohler service distributor/dealer for further fuel system installation information.

5.2 Fuel Lines

Note: Keep fuel lines away from the exhaust system.

Routing fuel lines. Take care when routing the fuel line from the fuel tank to the generator set. Keep the fuel lines as short as possible, but maintain adequate clearance from the exhaust system. Route the fuel lines along the frame or undercarriage; never route the fuel lines inside the occupied area of the vehicle. Connect the fuel line to the fuel pump. See Section 5.3 for the fuel pump lift.

Sizing fuel lines. Size the fuel line to handle the flow of fuel and to withstand road shock and year-round climate conditions. Use steel tubing as the codes require. Use a 6 mm (1/4 in.) ID tubing with an 230 mm (8 in.) (minimum) flexible section to allow free movement of the generator set.

Flexible hose sections. If a metal fuel line draws fuel from the fuel tank, install a flexible hose section to connect the metal line to the fuel pump. The flexible section allows generator set vibrational motion during operation. See Section 7 for the fuel-inlet-line size and connection point.

5.3 Fuel Pump Lift

See Figure 5-2 for the fuel pump lift capability. Do not exceed 24.1 kPa (3.5 psi) fuel pump pressure to the carburetor.

Note: Fuel system alterations may adversely affect emissions levels. Fines resulting from higher than allowable emissions levels are the responsibility of the user.

Model	Fuel Pump Lift m (ft.)
5ERKM/4EFRKM	0.9 (3)

Figure 5-2 Fuel Pump Lift Capability (Max.)

5.4 Fuel Consumption

Consult the generator set specification sheet for the generator set fuel consumption rates.

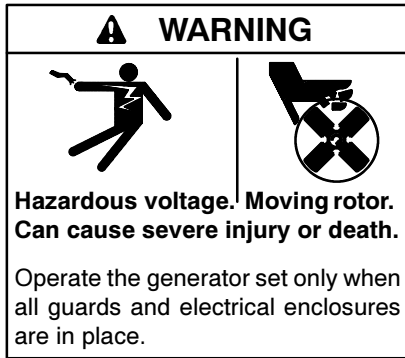

Electrical backfeed to the utility. Hazardous backfeed voltage can cause severe injury or death. Connect the generator set to the building/campground electrical system only through an approved device and after the building/campground main switch is opened. Backfeed connections can cause serious injury or death to utility personnel working on power lines and/or personnel near the work area. Some states and localities prohibit unauthorized connection to the utility electrical system. Install a transfer switch to prevent interconnection of the generator set power and other sources of power.

6.1 Electrical Connections

Have qualified electricians make electrical connections. Connections to the load leads, battery, and remote switch panel complete the installation. To prevent unintentional starting, make final connections to the battery only after making all other connections.

The following paragraphs provide details on each connection. Refer also to the wiring diagram in the operation manual.

Securely support or harness all wiring to the generator set to prevent abrasion. Provide additional support for the wiring to prevent exposure to the exhaust system and drippage of fuel, oil, or grease. Allow at least a 38.1 mm (1.5 in.) clearance between the electrical wiring and hot exhaust parts. Do not locate the wiring directly below or near the fuel system parts or the oil-fill tube.

Note: At the time of installation, make the wiring connections accessible for service and inspection.

6.2 AC Load Lead Connections

Routing. Each generator set has four color-coded load leads. The black leads (L1 and L2) are hot, the white lead (L0) is neutral, and the green lead is the hazard ground. See Section 8 for the AC load lead connections. Route the load leads directly from the junction box to the vehicle AC circuit. Route the load leads of all installations through flexible conduit from the generator end bracket to the junction box. Keep the load lead junction box accessible for service and inspection.

Note: Keep the load lead circuit away from the generator fuel and exhaust system components.

Note: Use field-supplied wiring capable of withstanding temperatures of 75°C (167°F).

Connect the neutral of the AC circuit in the vehicle to the lead L0 (white or gray). If the vehicle uses equipment-ground-type plugs and receptacles (3-pronged), connect the green wire to the U-shaped pin.

Note: AC load circuit protection. Protect the AC load circuit of the generator set against overloading or short circuiting with a circuit breaker(s).

Note: Canadian installations only. For standby service, connect output of the generator set to a suitably rated transfer switch in accordance with the Canadian Electrical Code, Part 1.

⚠ WARNING

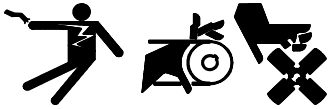

**Accidental starting.
Can cause severe injury or death.**

Disconnect the battery cables before working on the generator set. Remove the negative (-) lead first when disconnecting the battery. Reconnect the negative (-) lead last when reconnecting the battery.

Disabling the generator set. Accidental starting can cause severe injury or death. Before working on the generator set or equipment connected to the set, disable the generator set as follows: (1) Disconnect the power to the battery charger, if equipped. (2) Remove the battery cables, negative (-) lead first. Reconnect the negative (-) lead last when reconnecting the battery. Follow these precautions to prevent the starting of the generator set by the remote start/stop switch.

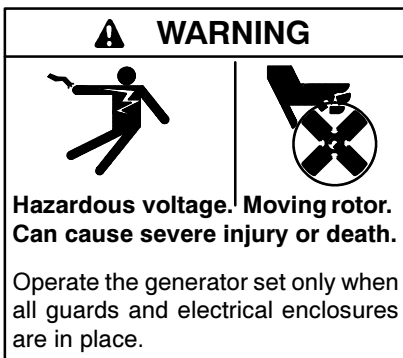

Grounding electrical equipment. Hazardous voltage can cause severe injury or death. Electrocutation is possible whenever electricity is present. Open the main circuit breakers of all power sources before servicing the equipment. Configure the installation to electrically ground the generator set, transfer switch, and related equipment and electrical circuits to comply with applicable codes and standards. Never contact electrical leads or appliances when standing in water or on wet ground because these conditions increase the risk of electrocution.

Short circuits. Hazardous voltage/current can cause severe injury or death. Short circuits can cause bodily injury and/or equipment damage. Do not contact electrical connections with tools or jewelry while making adjustments or repairs. Remove wristwatch, rings, and jewelry before servicing the equipment.

Electrical backfeed to the utility. Hazardous backfeed voltage can cause severe injury or death. Connect the generator set to the building/campground electrical system only through an approved device and after the building/campground main switch is opened. Backfeed connections can cause serious injury or death to utility personnel working on power lines and/or personnel near the work area. Some states and localities prohibit unauthorized connection to the utility electrical system. Install a transfer switch to prevent interconnection of the generator set power and other sources of power.

6.3 Circuit Protection

See an authorized service distributor/dealer for AC circuit breaker ratings, application, and selection information. The unit's voltage configuration determines the circuit breaker selection.

Note: Circuit breaker ampere rating and availability are subject to change.

The AC circuit breakers protect the generator set from extreme overload. AC circuit breakers trip when they detect a fault in the output circuit. After correcting the fault, reset the AC circuit breaker(s) by placing them in the ON position. Restart the unit.

6.3.1 Circuit Breaker Considerations

Mounting location. Mount the circuit breakers in the generator set controller.

Sizing. Use the generator set voltage/frequency configuration to determine the circuit breaker amperage. If the generator set voltage configuration changes, change the circuit breaker accordingly to provide optimum protection.

Have a qualified electrician or technician install circuit breakers and reconnect the generator set. Comply with all governing standards and codes.

6.3.2 Circuit Breaker Installation (Only Required for Changing from Factory-Installed and -Wired, 120-Volt, 2-Wire)

Note: Wire material. Use stranded copper for all wiring. Use wire gauges and insulation, conductor temperature ratings, sheath stripping, conductor support and protection, conductor terminals and splices, and overcurrent protection (circuit breakers, fuses) that conform to standards and codes.

Note: Wire protection. Use rubber grommets and cable ties as necessary to protect and secure the wiring from sharp objects, the exhaust system, and any moving parts.

1. Place the generator set start/stop switch in the STOP position and disconnect the generator set engine starting battery, the negative (-) lead first.
2. Remove the controller cover screws and remove the controller access cover.
3. Remove the screws and nuts to remove the circuit breaker cover plate. Save the mounting hardware.
4. Install the circuit breaker from the inside of the cutout panel and mount it using the existing screws removed in step 3. Position the circuit breaker with ON in the normal upright position or to the left side. Cover the cutout opening, if applicable, with the circuit breaker cover plate using the existing screws and nuts.
5. See Section 8 for voltage reconnection.
6. Install insulation boots over the stator lead terminals if the kit includes insulation boots.

Note: See Section 8 for wiring instructions.

7. Make the recommended connections for the following three reconnection systems using circuit breakers.

Two-pole circuit breaker with a single-voltage system (example: 120-volt, 3-wire).

Attach stator leads marked 2 and 4 to the side of the circuit breaker marked LINE. Install the jumper lead across the LINE side of the circuit breaker terminals (see Section 8). Attach stator leads 1 and 3 to L0.

Two-pole circuit breaker with a dual-voltage system (example: 120/240-volt, 3-wire).

Attach stator leads marked 1 and 4 to the side of the circuit breaker marked LINE. Do not use a jumper lead (see Section 8). Attach stator leads 2 and 3 to L0.

Single-pole circuit breaker with a single-voltage system (example: 240-volt, 2-wire).

Attach the stator lead marked 2 to the side of the circuit breaker marked LINE (see Section 8). Bolt together leads 1 and 4 and tape the leads to insulate them from ground. Attach the stator lead marked 3 to L0.

8. Connect the stator lead(s) used for neutral connection to the L0 stud. See illustrations in Section 8.
9. Connect the side of the circuit breaker marked LOAD to the transfer switch or vehicle. Attach insulation boots to the black leads if the kit includes insulation boots. With a single-pole circuit breaker use one black lead L1. With a two-pole circuit breaker use two black leads L1 and L2. Connect the neutral (white) lead to the L0 stud. Connect the equipment ground (green) lead to the GRD. stud.
10. Replace the controller cover or circuit breaker box access panel.
11. Reconnect the generator set engine starting battery, negative (-) lead last.
12. For voltage or frequency adjustments, refer to the procedure in Section 8.2.

6.4 Battery and Connections

WARNING



**Sulfuric acid in batteries.
Can cause severe injury or death.**

Use protective goggles and clothes. Battery acid can cause permanent damage to eyes, burn skin, and eat holes in clothing.

Battery gases. Explosion can cause severe injury or death. Battery gases can cause an explosion. Do not smoke or permit flames or sparks to occur near a battery at any time, particularly when it is charging. To prevent burns and sparks that could cause an explosion, avoid touching the battery terminals with tools or other metal objects. Remove wristwatch, rings, and other jewelry before handling the battery. Never connect the negative (-) battery cable to the positive (+) connection terminal of the starter solenoid. Do not test the battery condition by shorting the terminals together. Sparks could ignite the battery gases or fuel vapors. Ventilate the compartments containing batteries to prevent accumulation of explosive gases. To avoid sparks, do not disturb the battery charger connections while the battery is charging. Always turn the battery charger off before disconnecting the battery connections. Remove the negative (-) lead first when disconnecting the battery. Reconnect the negative (-) lead last when reconnecting the battery.

Starting battery. Kohler Co. recommends a separate 12-volt battery for the generator set. A separate battery allows closer installation to the generator set and minimizes cable length and voltage drop. See Figure 6-1 for the minimum cold cranking amps (CCA) battery recommendation.

Model	CCA
5ERKM/4EFRKM	250

Figure 6-1 Battery Recommendation

Lengths and sizes. See Figure 6-2 for the lengths and recommended sizes of the battery cables.

Cable connections. See Section 7 for the battery positive and negative connection points. Refer to Figure 6-3 for cable connections. (Note that installers must connect a ground strap between the ground lug on the generator set and the vehicle frame.)

Note: Ensure a ground connection between the generator and the vehicle frame.

Distance between Generator Set and Battery, m (ft.)	Cable Size (AWG)		
	At -18°C (0°F)	At 0°C (32°F)	At 24°C (75°F)
12.2 (40)	0	0	1
9.1 (30)	0	1	2
7.6 (25)	1	2	4
6.1 (20)	2	2	6
4.6 (15)	2	4	6
3.0 (10)	4	6	8
1.5 (5)	6	6	8
0.8 (2.5)	8	8	8

Figure 6-2 Battery Cable Sizes

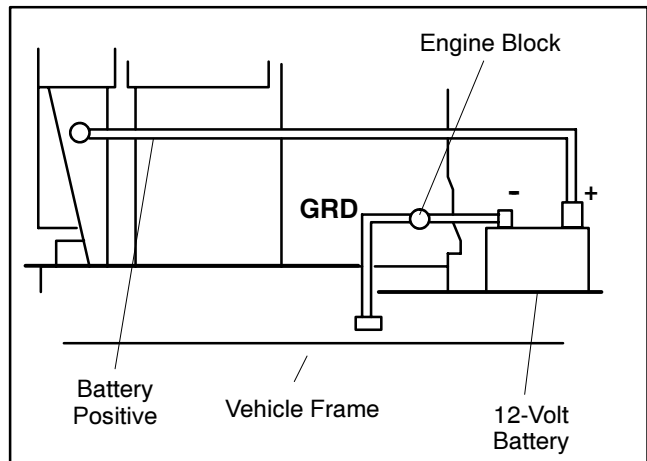

Figure 6-3 Battery Connection Details

6.5 Remote Switch Connection

Controllers include an accessory plug (P3) for easy connection to the remote start panel kit including the following:

- Hourmeter
- Start/Stop switch

One end of the 38.1 cm (15 in.) P3 wiring harness plugs directly into the controller. The pigtail leads on the remaining end of the harness connect to the remote panel terminals via customer-supplied wiring. Connect the remote operating controls to the P3 wire harness lead. See the wiring diagram in the operation manual to identify the P3 harness connections.

Section 7 Installation Drawing

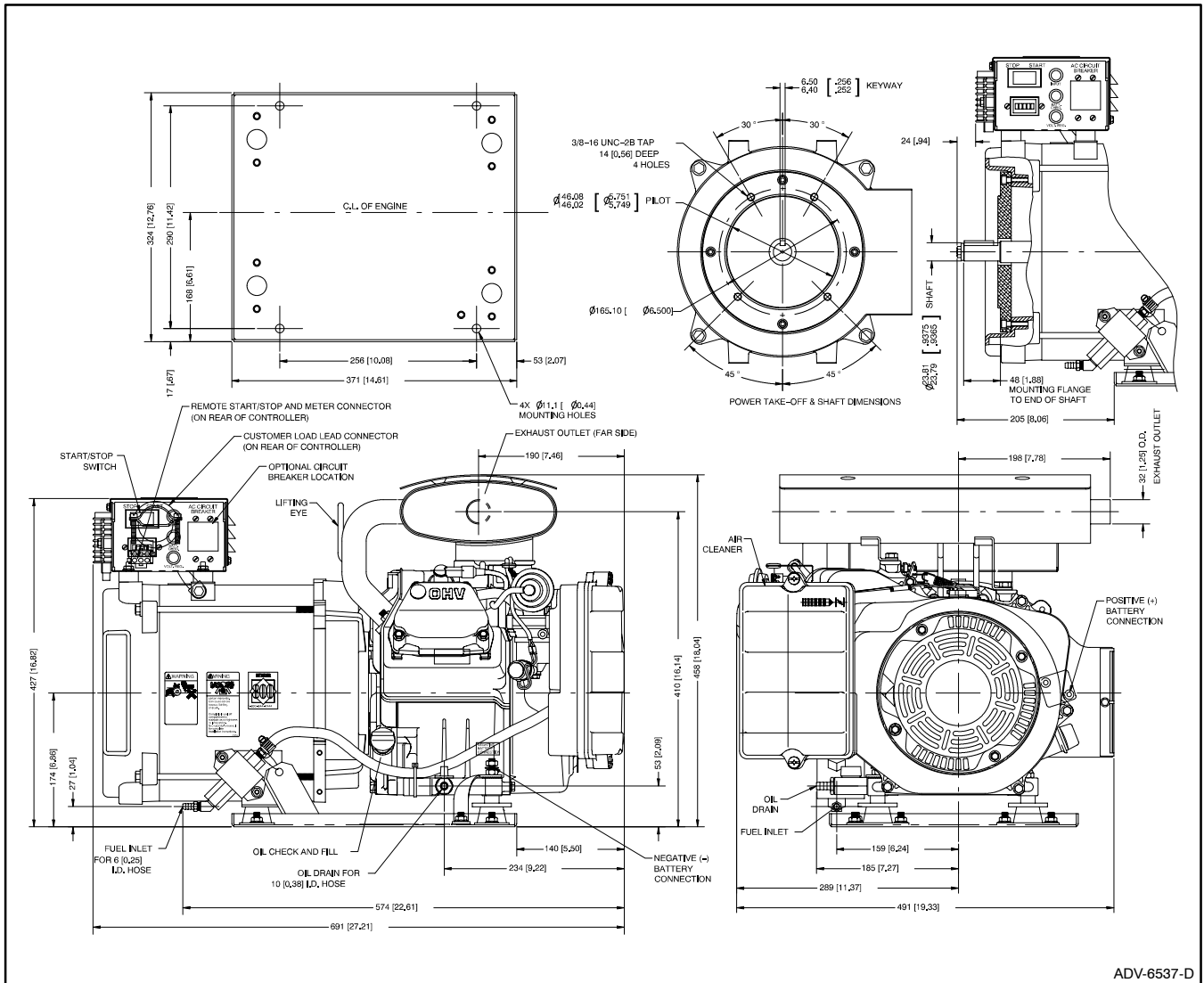

ADV-6537-D

Figure 7-1 Dimension Drawing

Notes

Section 8 Reconnection/Adjustments

8.1 Four-Lead Reconnection

The following drawings illustrate the reconnection of four-lead generator sets. In all cases, conform to the National Electrical Code (NEC).

NOTICE

Voltage reconnection. Affix a notice to the generator set after reconnecting the set to a voltage different from the voltage on the nameplate. Order voltage reconnection decal 246242 from an authorized service distributor/dealer.

100-120-Volt Configurations

If the installation requires a factory two-pole circuit breaker, do not connect the load-side terminals of the circuit breaker. See Figure 8-1. If the installation requires a 100-120-volt, 2-wire system, use a single-pole circuit breaker. See Figure 8-2. When connecting stator phase leads together, size the output lead (L1) to handle the amperage. Use a jumper lead on the *line* side of the circuit breaker to balance the load of the generator set.

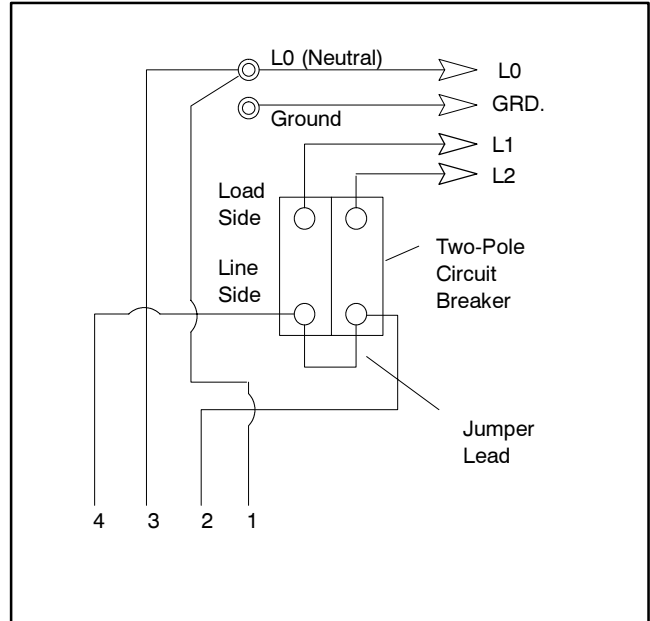

Figure 8-1 100-120-Volt, 3-Wire Configuration

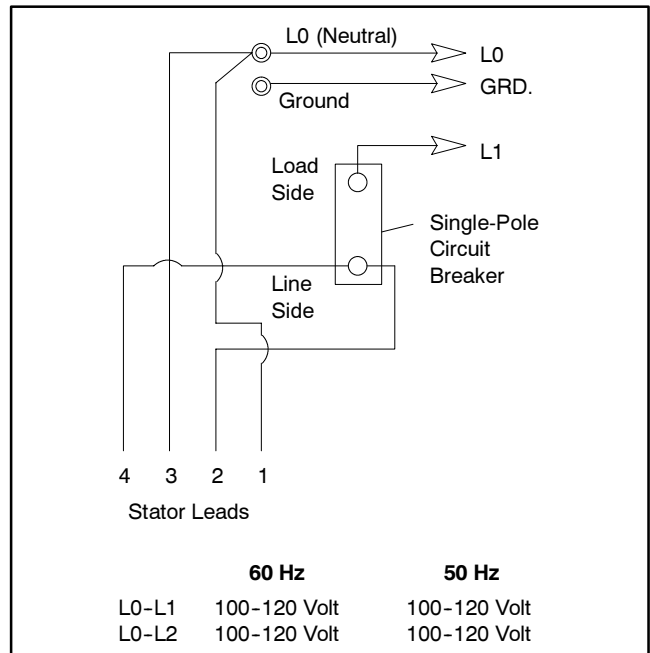

Figure 8-2 100-120-Volt, 2-Wire Configuration (Factory-Installed and -Wired)

100-120/200-240-Volt Configurations

The 100-120/200-240-volt configuration does not use a jumper lead. If the unit was originally wired for straight 100-120 volt, 3 wire, remove the jumper lead (see Figure 8-1 for location). Select a two-pole circuit breaker. Application of two single-pole circuit breakers does not conform to NEC requirements for supplying a 200-240 volt load, even if the breakers are mechanically attached. Leads L1 and L2 are for different phases; *never* connect them.

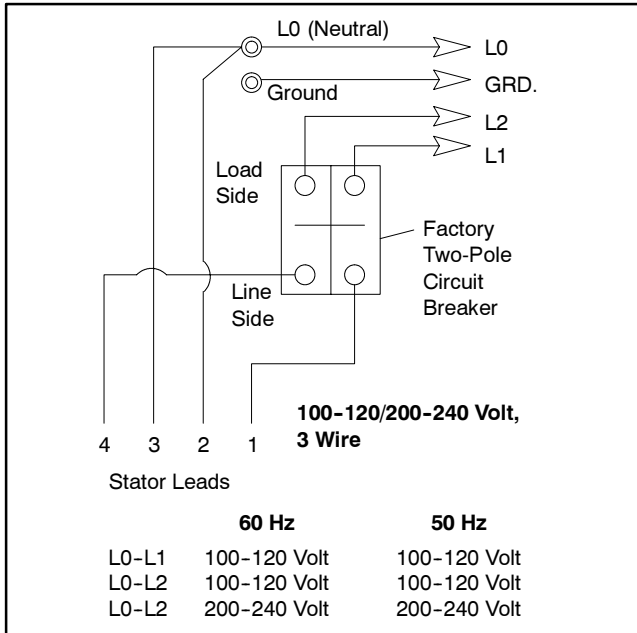

Figure 8-3 100-120/200-240-Volt, 3-Wire Configuration

200-240-Volt Configurations

The 200-240-volt configuration does not use a jumper lead. If the unit was originally wired for straight 100-120 volt, 3 wire, remove the jumper lead (see Figure 8-1 for location).

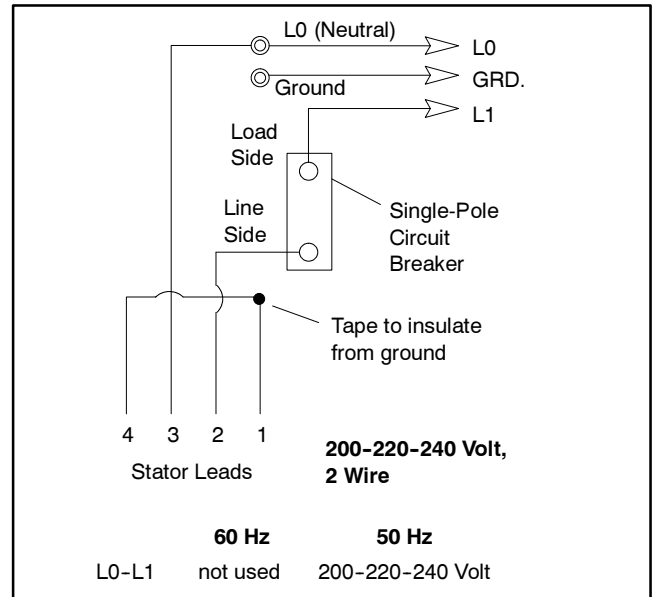
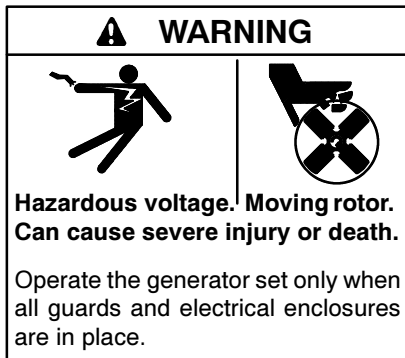

Figure 8-4 200-220-240-Volt, 2-Wire Configuration

8.2 Voltage Regulator Adjustment



Testing the voltage regulator. Hazardous voltage can cause severe injury or death. High voltage is present at the voltage regulator heat sink. To prevent electrical shock do not touch the voltage regulator heat sink when testing the voltage regulator.

(PowerBoost™, PowerBoost™ III, and PowerBoost™ V voltage regulator models only)

The controller contains the voltage regulator. Voltage regulator adjustments are possible without removing the voltage regulator. The voltage regulator adjustment procedure applies to the PowerBoost™ III E (Figure 8-5) voltage regulator.

Note: The following adjustment procedure is for readjustment of the voltage regulator and governor for broadrange generator sets with mechanical governors.

Note: Special Tools: Frequency meter 50/60 Hz.

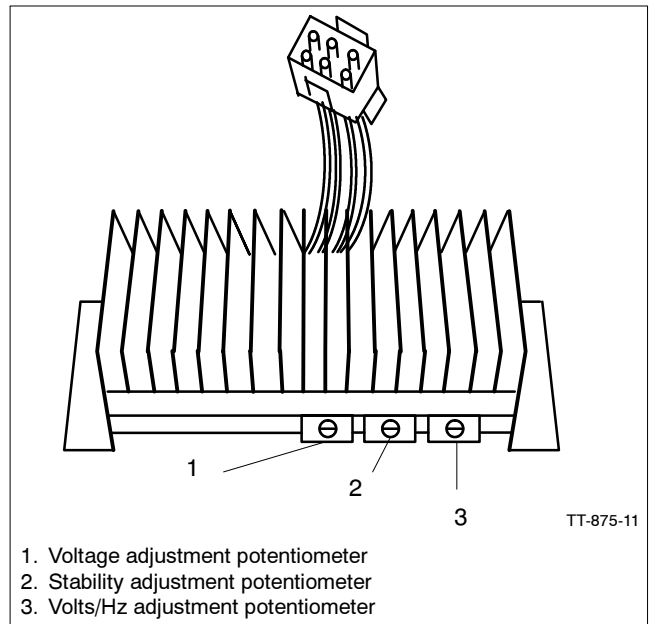

Figure 8-5 PowerBoost™ III E Voltage Regulator

Note: To adjust the generator output voltage from a location remote from the set, connect a customer-provided rheostat across regulator leads/terminals 33 and 66. The rheostat (10 kOhm, 1/2 watt minimum) provides a 5-volt adjustment range.

See Figure 8-5 to identify the potentiometers on the PowerBoost™ III E voltage regulator.

Stabilizer Potentiometer. Fine-tunes the regulator circuitry to reduce light flicker.

Voltage Adjustment Potentiometer. Adjusts the generator voltage output within a range of approximately 100–130 volts.

Volts/Hz Potentiometer. Determines the engine speed (Hz) at which the generator output voltage begins to drop.

Note: For optimum results, apply full load for voltage regulator adjustment.

Voltage Regulator Adjustment Procedure

1. With the generator set off, turn the remote rheostat, if equipped, to midpoint.
2. Turn the *voltage, volts/Hz, and stability potentiometers* fully counterclockwise.
3. Connect the voltmeter and frequency meter to the AC circuit or an electrical outlet.
4. Start the generator set.
5. Rotate the *voltage adjustment potentiometer* clockwise to increase the voltage (counterclockwise to decrease the voltage) to the desired output voltage.
6. Rotate the *stability potentiometer* clockwise to minimize light flicker.
7. Readjust the *voltage adjustment potentiometer*, if necessary.
8. Adjust the engine speed to the desired cut-in frequency (factory setting 57.5–58 Hz for 60-Hz models) as measured on the frequency meter.
9. Rotate the *volts/Hz adjustment potentiometer* clockwise until the voltage level (as measured on voltmeter) begins to drop. When set to these specifications, the generator attempts to maintain normal output until the engine speed drops below the frequency set in step 5 (as load is applied).
10. Readjust the engine speed to normal (63 Hz/ 1890 rpm for 60 Hz).
11. Readjust the *voltage adjustment potentiometer*, if necessary.
12. Readjust the *stability potentiometer*, if necessary.
13. Use the remote rheostat, if equipped, to make final voltage adjustments.
14. Stop the generator set.

Appendix A Generator Selection and Wattage Requirements

Consider total wattage requirements (lights, motors, appliances) when selecting a generator set or when sizing wattage usage in which available space and construction limit the size of the generator set.

Motors

When figuring generator set capacity requirements for loads that include electric motors, consider the high current demanded by the motors during startup. The inrush or starting current is typically 2-3 times higher than that required when the motor reaches normal operating speed. Allow reserve for inrush demands plus other loads which could be on the line as the electric motor starts. Use Figure 1 as a guide when selecting generator set capacity requirements involving motor loads.

Motor HP	Starting (Inrush) Watts	Running Watts
1/4	750	330
1/3	1000	400
1/2	1500	600
3/4	2000	750
1	3300	1100
2	4000	2000
3	5000	3000

Figure 1 Motor Requirements

Lighting

To calculate lighting load, add the wattage of each generator set-operated lamp. Note that not all of the lights or lamps are on the generator set AC circuit; some are DC powered by a 12-volt battery. Make sure the calculated total wattage includes only lights actually on the generator set AC circuit.

Air Conditioners

The starting characteristics of air conditioners vary greatly; one 12,000 Btu unit has, for example, lower starting requirements than a 10,000 Btu unit of another variety. When using only one unit, there is usually no starting problem, provided the lighting and appliance load is not too high when starting the unit.

Simultaneous starting of two air conditioning units, however, can present problems if the generator set capacity is marginal. Because of the variation in starting characteristics among air conditioners, this publication makes no statements regarding multiple-motor starting capabilities of the generator set covered. Consider delayed starting or use of easy-starting devices on air conditioner units whenever simultaneously starting more than one motor.

See Figure 2 for typical air conditioner requirements. Information will vary with manufacturer.

Appliances

Generator sets often furnish AC for appliances such as TV, stereo, electric water heater, etc. With the exception of the resistance-type loads such as the water heater, requirements for appliances are usually low. Do not overlook such loads when figuring total requirements. Allow reserve capacity for anticipated appliance loads to avoid overloading a generator set.

	Air Conditioner Size (Btu/Hr.)								
	7,000		9,000		12,000		16,000		24,000
Voltage	115	230	115	230	115	230	115	230	230
Full load amps	9.3	4.8	9.9	5.0	11.8	6.3	16.3	8.0	11.6
Rated load amps	7.7	4.0	7.0	3.5	8.9	4.8	13.0	6.2	10.2
Locked rotor amps	34.0	20.0	40.0	20.0	50.0	31.0	75.0	36.0	56.0
Starting (inrush) watts	3910	4600	4600	4600	5750	7130	8630	8280	12,900
Running watts	886	920	805	805	1020	1100	1500	1430	2350

Figure 2 Typical Marine Air Conditioner Requirements, 60 Hz

Appendix B Abbreviations

The following list contains abbreviations that may appear in this publication.

A, amp	ampere	CG	center of gravity	F	Fahrenheit, female
ABDC	after bottom dead center	CID	cubic inch displacement	fglass.	fiberglass
AC	alternating current	CL	centerline	FHM	flat head machine (screw)
A/D	analog to digital	cm	centimeter	fl. oz.	fluid ounce
ADC	analog to digital converter	cmm	cubic meters per minute	flex.	flexible
adj.	adjust, adjustment	CMOS	complementary metal oxide substrate (semiconductor)	freq.	frequency
ADV	advertising dimensional drawing			FS	full scale
AHWT	anticipatory high water temperature	cogen.	cogeneration	ft.	foot, feet
AISI	American Iron and Steel Institute	COM	communications (port)	ft. lbs.	foot pounds (torque)
ALOP	anticipatory low oil pressure	conn.	connection	ft./min.	feet per minute
alt.	alternator	cont.	continued	g	gram
Al	aluminum	CPVC	chlorinated polyvinyl chloride	ga.	gauge (meters, wire size)
ANSI	American National Standards Institute (formerly American Standards Association, ASA)	crit.	critical	gal.	gallon
		CRT	cathode ray tube	gen.	generator
AO	anticipatory only	CSA	Canadian Standards Association	genset	generator set
API	American Petroleum Institute	CT	current transformer	GFI	ground fault interrupter
approx.	approximate, approximately	Cu	copper	gnd.	ground
AR	as required, as requested	cu. in.	cubic inch	gov.	governor
AS	as supplied, as stated, as suggested	cw.	clockwise	gph	gallons per hour
ASE	American Society of Engineers	CWC	city water-cooled	gpm	gallons per minute
ASME	American Society of Mechanical Engineers	cyl.	cylinder	gr.	grade, gross
assy.	assembly	D/A	digital to analog	gr. wt.	gross weight
ASTM	American Society for Testing Materials	DAC	digital to analog converter	H x W x D	height by width by depth
ATDC	after top dead center	dB	decibel	HC	hex cap
ATS	automatic transfer switch	dBA	decibel (A weighted)	HCHT	high cylinder head temperature
auto.	automatic	DC	direct current	HD	heavy duty
aux.	auxiliary	DCR	direct current resistance	HET	high exhaust temperature
A/V	audio/visual	deg., °	degree	hex	hexagon
avg.	average	dept.	department	Hg	mercury (element)
AVR	automatic voltage regulator	dia.	diameter	HH	hex head
AWG	American Wire Gauge	DI/EO	dual inlet/end outlet	HHC	hex head cap
AWM	appliance wiring material	DIN	Deutsches Institut fur Normung e. V. (also Deutsche Industrie Normenausschuss)	HP	horsepower
bat.	battery			hr.	hour
BBDC	before bottom dead center	DIP	dual inline package	HS	heat shrink
BC	battery charger, battery charging	DPDT	double-pole, double-throw	hsg.	housing
BCA	battery charging alternator	DPST	double-pole, single-throw	HVAC	heating, ventilation, and air conditioning
BCI	Battery Council International	DS	disconnect switch	HWT	high water temperature
BDC	before dead center	DVR	digital voltage regulator	Hz	hertz (cycles per second)
BHP	brake horsepower	E, emer.	emergency (power source)	IC	integrated circuit
blk.	black (paint color), block (engine)	EDI	electronic data interchange	ID	inside diameter, identification
blk. htr.	block heater	EFR	emergency frequency relay for example (<i>exempli gratia</i>)	IEC	International Electrotechnical Commission
BMEP	brake mean effective pressure	e.g.	for example (<i>exempli gratia</i>)	IEEE	Institute of Electrical and Electronics Engineers
bps	bits per second	EG	electronic governor	IMS	improved motor starting
br.	brass	EGSA	Electrical Generating Systems Association	in.	inch
BTDC	before top dead center	EIA	Electronic Industries Association	in. H ₂ O	inches of water
Btu	British thermal unit	EI/EO	end inlet/end outlet	in. Hg	inches of mercury
Btu/min.	British thermal units per minute	EMI	electromagnetic interference	in. lbs.	inch pounds
C	Celsius, centigrade	emiss.	emission	Inc.	incorporated
cal.	calorie	eng.	engine	ind.	industrial
CARB	California Air Resources Board	EPA	Environmental Protection Agency	int.	internal
CB	circuit breaker	EPS	emergency power system	int./ext.	internal/external
cc	cubic centimeter	ER	emergency relay	I/O	input/output
CCA	cold cranking amps	ES	engineering special, engineered special	IP	iron pipe
ccw.	counterclockwise	ESD	electrostatic discharge	ISO	International Organization for Standardization
CEC	Canadian Electrical Code	est.	estimated	J	joule
cfh	cubic feet per hour	E-Stop	emergency stop	JIS	Japanese Industry Standard
cfm	cubic feet per minute	etc.	et cetera (and so forth)	k	kilo (1000)
		exh.	exhaust	K	kelvin
		ext.	external	kA	kiloampere
				KB	kilobyte (2 ¹⁰ bytes)
				kg	kilogram

kg/cm ²	kilograms per square centimeter	mW	milliwatt	rnd.	round
kgm	kilogram-meter	μF	microfarad	ROM	read only memory
kg/m ³	kilograms per cubic meter	N, norm.	normal (power source)	rot.	rotate, rotating
kHz	kilohertz	NA	not available, not applicable	rpm	revolutions per minute
kJ	kilojoule	nat. gas	natural gas	RS	right side
km	kilometer	NBS	National Bureau of Standards	RTV	room temperature vulcanization
kOhm, kΩ	kilo-ohm	NC	normally closed	SAE	Society of Automotive Engineers
kPa	kilopascal	NEC	National Electrical Code	scfm	standard cubic feet per minute
kph	kilometers per hour	NEMA	National Electrical Manufacturers Association	SCR	silicon controlled rectifier
kV	kilovolt	NFPA	National Fire Protection Association	s, sec.	second
kVA	kilovolt ampere	Nm	newton meter	SI	<i>Systeme international d'unites</i> , International System of Units
kVAR	kilovolt ampere reactive	NO	normally open	SI/EO	side in/end out
kW	kilowatt	no., nos.	number, numbers	sil.	silencer
kWh	kilowatt-hour	NPS	National Pipe, Straight	SN	serial number
kWm	kilowatt mechanical	NPSC	National Pipe, Straight-coupling	SPDT	single-pole, double-throw
L	liter	NPT	National Standard taper pipe thread per general use	SPST	single-pole, single-throw
LAN	local area network	NPTF	National Pipe, Taper-Fine	spec, specs	specification(s)
L x W x H	length by width by height	NR	not required, normal relay	sq.	square
lb.	pound	ns	nanosecond	sq. cm	square centimeter
lbm/ft ³	pounds mass per cubic feet	O/C	overcrank	sq. in.	square inch
LCB	line circuit breaker	OD	outside diameter	SS	stainless steel
LCD	liquid crystal display	OEM	original equipment manufacturer	std.	standard
ld. shd.	load shed	O/F	overfrequency	stl.	steel
LED	light emitting diode	opt.	option, optional	tach.	tachometer
Lph	liters per hour	O/S	oversize, overspeed	TD	time delay
Lpm	liters per minute	OSHA	Occupational Safety and Health Administration	TDC	top dead center
LOP	low oil pressure	O/V	overvoltage	TDEC	time delay engine cooldown
LP	liquefied petroleum	oz.	ounce	TDEN	time delay emergency to normal
LPG	liquefied petroleum gas	oz.	ounce	TDES	time delay engine start
LS	left side	p., pp.	page, pages	TDNE	time delay normal to emergency
L _{wa}	sound power level, A weighted	PA	packed accessory	TDOE	time delay off to emergency
LWL	low water level	PC	personal computer	TDON	time delay off to normal
LWT	low water temperature	PCB	printed circuit board	temp.	temperature
m	meter, milli (1/1000)	pF	picofarad	term.	terminal
M	mega (10 ⁶ when used with SI units), male	PF	power factor	TIF	telephone influence factor
m ³	cubic meter	ph.	phase	TIR	total indicator reading
m ³ /min.	cubic meters per minute	PHC	Phillips head crimptite (screw)	tol.	tolerance
mA	milliampere	PHH	Phillips hex head (screw)	turbo.	turbocharger
man.	manual	PHM	pan head machine (screw)	typ.	typical (same in multiple locations)
max.	maximum	PLC	programmable logic control	U/F	underfrequency
MB	megabyte (2 ²⁰ bytes)	PMG	permanent magnet generator	UHF	ultrahigh frequency
MCM	one thousand circular mils	pot	potentiometer, potential	UL	Underwriter's Laboratories, Inc.
meggar	megohmmeter	ppm	parts per million	UNC	unified coarse thread (was NC)
MHz	megahertz	PROM	programmable read only memory	UNF	unified fine thread (was NF)
mi.	mile	psi	pounds per square inch	univ.	universal
mil	one one-thousandth of an inch	pt.	pint	U/S	undersize, underspeed
min.	minimum, minute	PTC	positive temperature coefficient	UV	ultraviolet
misc.	miscellaneous	PTO	power takeoff	U/V	undervoltage
MJ	megajoule	PVC	polyvinyl chloride	V	volt
mJ	millijoule	qt.	quart	VAC	volts alternating current
mm	millimeter	qty.	quantity	VAR	voltampere reactive
mOhm, mΩ	milliohm	R	replacement (emergency) power source	VDC	volts direct current
MOhm, MΩ	megohm	rad.	radiator, radius	VFD	vacuum fluorescent display
MOV	metal oxide varistor	RAM	random access memory	VGA	video graphics adapter
MPa	megapascal	RDO	relay driver output	VHF	very high frequency
mpg	miles per gallon	ref.	reference	W	watt
mph	miles per hour	rem.	remote	WCR	withstand and closing rating
MS	military standard	RFI	radio frequency interference	w/	with
m/sec.	meters per second	RH	round head	w/o	without
MTBF	mean time between failure	RHM	round head machine (screw)	wt.	weight
MTBO	mean time between overhauls	rly.	relay	xfrm	transformer
mtg.	mounting	rms	root mean square		
MW	megawatt				

TP-6082 4/00

© Kohler Co., 2000. All rights reserved.

KOHLER[®] POWER SYSTEMS

KOHLER CO. Kohler, Wisconsin 53044
Phone 920-565-3381, Web site www.kohlergenerators.com
Fax 920-459-1646 (U.S.A. Sales), Fax 920-459-1614 (International)
For the nearest sales and service outlet in U.S.A. and Canada
Phone 1-800-544-2444

Kohler[®] Power Systems
Asia Pacific Headquarters
7 Jurong Pier Road
Singapore 619159
Phone (65)264-6422, Fax (65)264-6455