

Battery Isolator
INSTALLATION INSTRUCTIONS

Models: 1-2-70, 1-3-70, 2-3-70,
1-2-120, 1-3-120, 2-3-120,
1-3-165

GENERAL INFORMATION:

This heavy duty NEWMAR battery isolator allows you to charge multiple battery banks from a single or dual (depending on model) charging source (typically an alternator, and referred to as such throughout these instructions). Conservatively rated diodes within the unit divide the charge among the batteries according to need and prevent a battery with a greater charge from "dumping" current into a battery with lesser charge. The isolator is rated for 12, 24, 32, 36 and 48 volt negative ground battery systems.

INSTALLATION:

Important: Read and understand these instructions completely before attempting the installation.

Ensure that your alternator is working properly before you start the installation. Poor or improper connections, hidden "shorts", undersized wires or connectors and corroded battery posts are all common causes of poor alternator performance or even complete failure.

Note: Unless modified, this battery isolator is not suitable for use with alternators that require external excitation voltage, as the internal diodes block this voltage. If you have this type of alternator, contact the factory for recommended modification.

Refer to the installation diagrams on the reverse of this page. Typical installations for single alternator and dual alternator applications are illustrated. *Note: The battery isolator is supplied with a set of wiring hardware. If the hardware packet is lost or missing from the packaging, contact the factory. Using incorrectly sized hardware on the wiring studs will damage the isolator. Stud sizes are as follows:*

70 amp models — 6 mm (1.0 pitch)
120 and 165 amp models — 8 mm (1.25 pitch)

1. Disconnect the negative (ground) side of any battery which will be wired to the isolator.
2. Mount the isolator as near to the alternator as possible, preferably in a location where it will receive ventilation. Do not mount it directly onto the engine block as excessive heat will reduce the current handling capability and possibly damage the isolator. Vertical mounting will facilitate cooler operation.
3. Locate the alternator output terminal. Remove the charging lead and attach it to the "# 1" battery isolator terminal. If it is necessary to cut this wire down to a more suitable length, terminate the end with a heavy duty ring lug connector. Note: For all terminals on 70 amp models use 6 mm ring lug connectors; for 120 and 165 amp models use 8 mm ring lug connectors.
4. Cut a wire of suitable length (stranded, not solid) to run from the alternator to the isolator. (Refer to the wire size table below to determine correct gauge.) Terminate one end with a heavy duty ring lug connector. Attach this end to the terminal marked "A" or "A1" on the battery isolator. Terminate the other end with a suitably sized ring lug connector and attach it to the alternator output terminal.



U.S.A. HEADQUARTERS
P.O. Box 1306, Newport Beach, CA 92663
Phone: 714-751-0488 Fax: 714-957-1621
E-Mail: sales@newmarpower.com

ELECTRONIC POWER PRODUCTS
COMMUNICATION • NAVIGATION
www.newmarpower.com

EURO WAREHOUSE
Phone: +31-35-603-2494 Fax: +31-35-603-2149
E-Mail: sales@newmarpower.com

5. Repeat steps 3 and 4 (using “# 2” for the second battery, “A2” for the second alternator, etc.) as necessary for additional batteries and/or alternators.

6. Reconnect the negative battery posts.

WIRE SIZE TABLE

ISOLATOR MODEL	ALTERNATOR RATING	WIRE LENGTH*	WIRE SIZE	
			AWG	mm
1-2-70	70 AMP	UP TO 10'	#6	16
1-3-70		11' - 25'	#4	25
2-3-70		25' - 40'	#2	35
1-2-120	120 AMP	UP TO 10'	#4	25
1-3-120		11' - 25'	#2	35
2-3-120		25' - 40'	#1	50
1-3-165	165 AMP	UP TO 10'	#2	35
		11' - 25'	#1	50
		25' - 40'	#0	70

* Note: WIRE LENGTH is the combined total of the longest run from alternator to isolator plus isolator to battery.

TYPICAL INSTALLATION DIAGRAMS

Note: These diagrams do not illustrate complete systems. Refer to ABYC Standard E-9) DC Electrical Systems on Boats

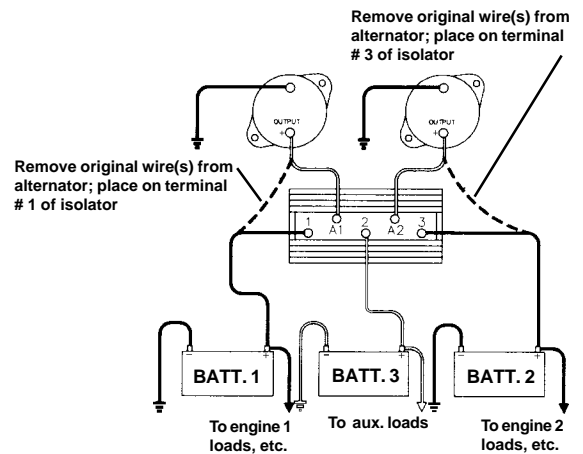
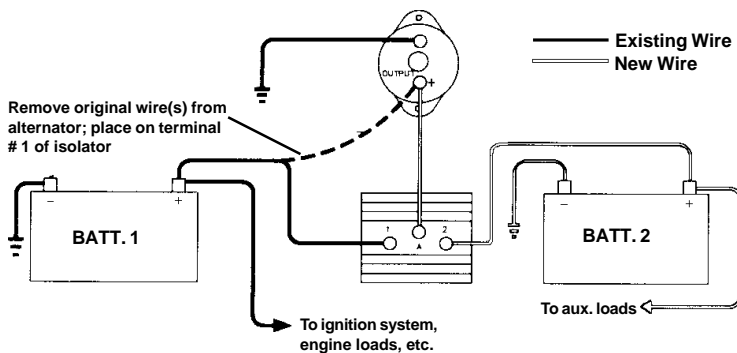

SPECIFICATIONS

- Operating Temperature:** -40 to +80° C
- Duty Cycle:** Continuous to 50° C; derate linearly to 70% @ 80° C
- Temperature Rise:** 95° C at full rated current
- Voltage Drop:** 0.7 VDC @ 50% load, 0.9 VDC @ full load



U.S.A. HEADQUARTERS
P.O. Box 1306, Newport Beach, CA 92663
Phone: 714-751-0488 Fax: 714-957-1621
E-Mail: sales@newmarpower.com

ELECTRONIC POWER PRODUCTS
COMMUNICATION • NAVIGATION
www.newmarpower.com

EURO WAREHOUSE
Phone: +31-35-603-2494 Fax: +31-35-603-2149
E-Mail: sales@newmarpower.com